

TERMS OF REFERENCE (TOR)

**RFP for Selection of Agency for Concrete Pillar Fixing work for Varanas- Gorakhpur Project
under North Eastern Railway**

Oct 04, 2024

Delhi Integrated Multi Modal Transit System Limited (DIMTS)

(A Joint Venture of Govt. of NCT of Delhi)

8th Floor, Block - 1, Delhi Technology Park,

Shastri Park, Delhi 110 053, India

E-mail: bpbd@dimts.in Website: <http://www.dimts.in>

TENDER RELATED INFORMATION

SN	Description	Date
1	Tender Release Date	Oct 04, 2024
2	Tender Submission Date	Oct 15, 2024 by 3 pm in DIMTS office
3	Tender Opening Date	Oct 15, 2024 at 3.30 pm in DIMTS office
4	Contact Person	Mr. Rakesh Kaul Contact : 011 – 43090217
5	Physical Submission of Tender	Yes
6	Submission of Proposal	By email to: rakesh.kaul@dimts.in

1. BACKGROUND

- 1.1 Delhi Integrated Multi-Modal Transit System Limited (DIMTS), a joint venture company between Government of National Capital Territory of Delhi (GNCTD), has been set up with an objective to augment public transport through integrated multi-modal network of mass transit system/s. It aims to provide user friendly public transport services and to set up a mechanism for growth of public transport to keep pace with growth in demand.
- 1.2 DIMTS is engaged in planning and development of transport centric infrastructural works and proposes to identify suitable agencies to assist itself in this task.

2. SCOPE OF SERVICES

- 2.1 DIMTS proposes to engage an agency who can execute Pillar fixing work for final location survey for Varanas- Gorakhpur (Aurnihar to Muradpur) Project under North Eastern Railway (NER) Projects.

SCOPE OF SERVICES

The Scope include Manufacturing, Supplying and Fixing of 1:2:4 pre-cast Cement Concrete Pillars of size as per drawing issued by NER (attached below) including painting with contractor's paint along the Proposed Railway alignment from Aurnihar to Muradpur in Railway Land with contractor's all materials, all labours, DGPS for co-ordinates, all lead, lift., desent, loading, unloading, sales tax, carriage, handling, cleaning sites etc. complete as directed by the Engineer-in-charge.

3. PAYMENT SCHEDULE

SN	Particulars	Unit	Qty.	Rate (In Rs)	Amount (In Rs)
A (i)	Manufacturing, Supplying and Fixing of 1:2:4 pre-cast Cement Concrete Pillars of size 450mm x 150mm x 150mm and fixing the same with 1:2:4 Cement Concrete of size 450mm x 250mm x 250mm after excavation of pit of size 450mm x 450mm x 450mm and refilling the pits including painting with contractor's paint along the Proposed Railway alignment in Railway Land as per Railway's drawings with contractor's all materials, all labours, all lead, lift., desent, loading, unloading, sales tax,	Nos	3000		

SN	Particulars	Unit	Qty.	Rate (In Rs)	Amount (In Rs)
	carriage, handling, cleaning sites etc. complete as directed by the Engineer-in-charge. (i) The pillar shall be fixed as per programme drawn in consultation with railway as per recommended guidelines the cost is inclusive of all labour and material *the GPS points of all the mattam/pillar shall be provided by us.				
	GST Amount				
	Total				

4. TERMS AND CONDITIONS

- Contractor shall mobilised the required resources at site for execution of pillar fixing work.
- Contractor shall maintain daily progress of installed pillar along with coordinates as per standards and satisfactory to the Client
- The Engineer will have the right to inspect any or all the equipment's of the contractor before starting the work or at any time during the progress of the work and the contractor shall remove from site and not use any such equipment's as have been found unsuitable.
- Cost of all materials, all tools including DGPS for Co-ordinates, plants, equipment's, sheds etc. required for the work and all charges on account of their transportation, handling, erecting, dismantling after work shall be included in the rates quoted by Sub-contractor and no extra payment will be made for these. The rates quoted shall include cost of all ancillary items of work, if any, to complete the work as described in the stipulated duration of time and no extra payment shall be admissible on this account.
- During the course of work, the contractor shall afford all facilities, at his own expense, to the Engineer for inspecting the works, taking measurements and for all other activities found necessary by the Engineer.

5. PAYMENT TERMS

- a) The Sub-contractor is entitled for payments from time to time based on approval letter issued by NER for installed pillar

- b) 95% of due Payment will be released within 30 days from certification of quantity issued by NER
- c) Balance 5% payment shall be released after 6 month of completion
- d) No mobilization advance will be paid to shortlisted Sub-contractor

6. METHOD OF SELECTION:

- i. Selection will be on Least cost basis.
- ii. It is intended to award the work to one agency, however, in case of large price variations, the company reserves the right to award the work to more than one agency, based on such price and quality considerations.
- iii. Technical proposal shall be restricted to 10 pages.

Note:

- a) Part Bid i.e. covering only part of the scope of services will not be accepted.
- b) Technical and Price Quote: To be submitted only in physical form.

7. TERMINATION OF THE AGREEMENT

- a) The Agreement may be terminated if any Party is in breach of any of its obligations under the Agreement and the breach has not been remedied within fourteen (14) days (or longer period as the notifying Party may allow) of the intimation to the Party in breach requiring the breach to be remedied. Provided that the Consultant shall not terminate this Agreement without the prior written approval of DIMTS.
- b) In the event of total default / failure of the firm in the execution of the services, DIMTS reserves the right to get the work executed by any other consultancy firm at the cost and risk of the defaulting consultancy firm.
- c) If DIMTS terminates the Agreement as a result of a default of the agency, the agency shall be liable for the extra costs reasonably incurred by DIMTS in obtaining completion of that part of the Services which remained incomplete as at the date of termination.
- d) If DIMTS terminates the agreement, not as a result of any default by the agency, then DIMTS shall compensate the agency for the work performed till the date of notice of termination.

8. RESPONSIBILITIES AND OBLIGATIONS OF THE AGENCY

The Agency shall:

- a) Have no right on the updated data which shall be customized as per the requirements of DIMTS.
- b) All Intellectual Propriety Rights shall wrest with DIMTS.
- c) Provide the Services in accordance with Scope of Services.
- d) Exercise the degree of skill, care and diligence normally exercised by members of the profession performing services of a similar nature ;
- e) Be bound to comply with any written direction of DIMTS to vary the scope sequence or timing of the Services ;
- f) Use all reasonable efforts to inform itself of DIMTS's requirements for the Deliverables for

which purpose the Agency shall consult DIMTS throughout the performance of the Services;

- g) Shall be responsible for any error/omission in the data used for the services and shall verify the same at his own risk and cost including preparation of fresh drawings/ reports etc. as called for.
- h) Make presentations to DIMTS as and when required by client.

9. RESPONSIBILITIES AND OBLIGATIONS OF DIMTS

- a) DIMTS shall provide to the agency all relevant reports on the Assignment and other documents/ information/ reports as available with DIMTS and as may be required by the agency to enable it to provide the services to DIMTS. DIMTS undertakes and agrees to furnish to the agency from time to time such other documents/ reports/ information in its possession and/or knowledge as it may consider relevant to perform the Services, as and when such information is received by/ available with the DIMTS.
- b) All work prepared by the agency in performing the Services shall become and remain the property and copyright of DIMTS after payment therefor, and the agency shall, not later than upon termination or expiration of this Agreement, deliver all of the foregoing to DIMTS.
- c) The Agency shall treat the details of the output of the assignment and the Services as confidential and for the Agency's own information only and shall not publish or disclose the details of the output, deliverables / milestones submitted to DIMTS or the Services in any professional or technical journal or paper or elsewhere in any manner whatsoever without the previous consent in writing of DIMTS.

10. AGENCY'S REPRESENTATIVES

The Agency shall appoint a representative, and agree that the person appointed shall have authority to act on behalf of the Agency for all purposes in connection with the Services and in accordance with all the provisions under the Agreement.

11. COMPLIANCE WITH LAWS

The Agency shall take due care that all its documents comply with all relevant laws and statutory regulations and ordinances, guidelines in force which includes all laws in force and effect as of the date hereof and which may be promulgated or brought into force and effect hereinafter in India including judgements, decrees, injunctions, writs of or orders of any court of record, as may be in force and effect during the subsistence of this Agreement applicable to the Agency.

12. GOVERNING LAW AND SETTLEMENT OF DISPUTES

- a) The Agreement shall be governed by the laws of India at Delhi.
- b) Continuation with the Services
Notwithstanding the existence of a dispute, the Agency shall at all times continue to fulfill all its obligations under the Agreement and comply with all directions given to the Agency by DIMTS in accordance with the Agreement.
- c) Procedures for Resolution
 - i. Save where expressly stated to the contrary in this Agreement, any dispute,

difference or controversy of whatever nature between the Parties, howsoever arising under, out of or in relation to this Agreement, shall in the first instance be attempted to be resolved amicably by meetings between the Parties.

- ii. Any dispute, which is not amicably resolved by the Parties, shall be finally settled by the Managing Director, DIMTS, whose decision shall be final and binding on both the Parties.
- iii. Pending submission of and/or decision on a dispute, the Parties shall continue to perform their respective obligations under this Agreement without prejudice to a final adjustment in accordance with the decision of the Managing Director, DIMTS.

13. MODIFICATION

Modification of the terms and conditions of the Agreement, including any modification of the scope of the Services, may only be made by written agreement between the Parties.

14. INDEMNIFICATION

The Agency shall keep DIMTS both during and after the term of this Agreement fully and effectively indemnified against all losses, damages, injuries, deaths, expenses, actions, proceedings, demands, costs and claims including, but not limited to, legal fees and expenses, suffered by DIMTS, where such loss, damages, injury or death is the direct result of the wrongful action, negligence, or breach of Agreement of the Agencies or their sub-agencies, or the personnel or agents of either of them, including the use or violation of any copyright work or literary property or patented invention, article or appliance.

15. TRANSFER OR ASSIGNMENT

No Party may assign its interests in the Agreement without the prior written consent of the other Party. Unless specifically stated to the contrary, in any written consent to an assignment, no assignment shall release or discharge the assignor from any obligation under this Agreement.

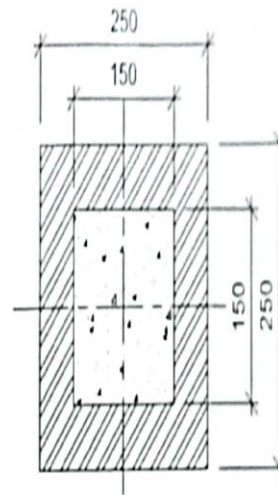
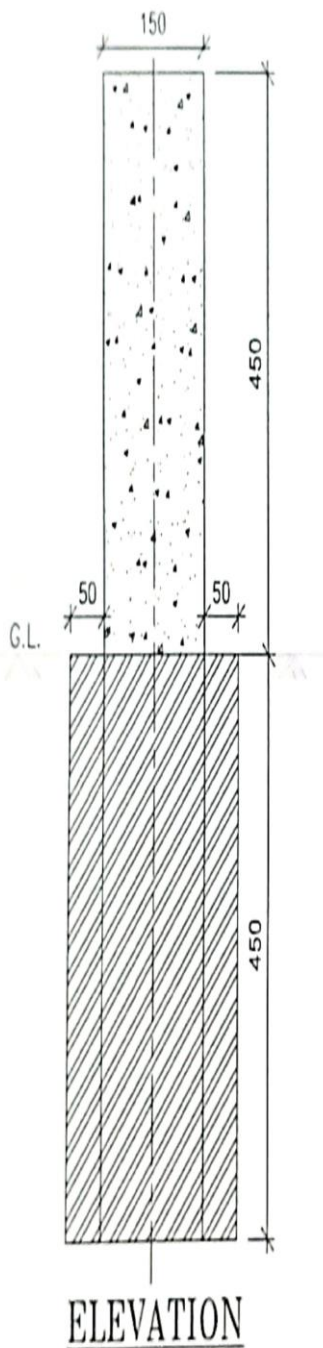

NOTE: ALL DIMENSIONS ARE IN MM.

SIGNATURE BOX	
By: CE.CONV.GRP	
XEN.CON.SURVEY.GRP	
SIE.CON.WORK.GRP	

NORTH EASTERN RAILWAY
(CONSTRUCTION ORGANISATION)



PROJECT:

Carrying out drone based photogrammetry (LEAP) Survey for Detailed Engineering of project including Alignment, leveling, Geotechnical investigation, hydrological investigations, preparation of plans, and 6 sections. General arrangement drawings (GAD) of bridges, set of quantities and other ancillary activities. Also preparation of DPR in consultation with Free Consultancy Survey to a new line in between Jorhat and Golaghat via Lajpat and Apatpatra section 116.810 of North Eastern Railway.

TITLE: CENTER LINE PILLAR SECTION DRAWING

SCALE: NOT TO SCALE

PROJECT CONSULTANT:

DELHI INTEGRATED MULTI-MODAL TRANSIT SYSTEM LTD.
80 Floor, Block 1, Delhi Technology Park,
Gurgaon, Haryana - 122002

